

Turbo Pro™ Multivariable Flowmeter

Model Pro-T™ Insertion Turbine Mass Flow Meter



VorTek Instruments' Model Pro-T™ multivariable flowmeters utilize three primary sensing elements—a turbine sensor, an RTD temperature sensor, and a solid-state pressure transducer—to measure the mass flow rate of gases, liquids and steam. Because the TurboPro™ is able to measure all process variables within a single device it provides exceptional accuracy, simplifies system design and reduces installation costs.

They are easily installed with flanged or Male NPT process connections in any pipe size of two-inches and greater. Optional retractor or “hot-tap” hardware simplifies maintenance operations.

TurboPro™ Model Pro-T™ provides excellent rangeability and can measure very low flow rates with negligible permanent pressure drop. Additionally rotors are interchangeable, making this meter a good choice for installations with step changes in seasonal flow rates. To simplify installation and commissioning, all measured variables and programming menus are available on the instrument's easy to use display and control pad. The product line is available with a wide range of options and meter configurations to meet your specific application requirements.

Pro-T™ Advantage:

- Volumetric or mass flow monitoring of most liquids, gases, and steam
- Multivariable meter delivers mass flow, temperature, pressure, and density readings from a single installed device and reduces initial cost, installation cost and cost-of ownership over the lifetime of the instrument
- Compensated mass flow reading of liquids, gases, and steam
- Easy to install and commission—hot tappable, process shut down not required for installation
- High accuracy with rangeability up to 17:1
- Temperature -450 to 850°F
- Pressure up to 2250 psig
- Insertion style mounting permits installation in any pipe 3” and greater
- Field configurable ranges, outputs and displays
- Remote electronics option available for use in harsh environments or locations with limited access
- 4-20mA loop-powered mass meter design saves on energy costs
- HART protocol communications - Standard
- Modbus, BACnet communications available
- FM, FMC, ATEX, IECEx Approved



VorTek
INSTRUMENTS
VorTek Instruments, LLC

8475 West I-25 Frontage Rd., Suite 300
Longmont, CO 80504 USA
Tel: 303/682-9999 Fax: 303/682-4368
info@vortekinst.com

TurboPro™ Principle of Operation

Insertion turbine flow meters measure flows of liquid, gas, and steam by detecting the frequency of rotation of the turbine blades. According to the proven laws of physics, the frequency at which the turbine rotates is directly proportional to the flow velocity.

Insertion turbine flow meters measure flow by detecting the local velocity at a strategically located position within the pipe. The TurboPro™ detects the frequency within the sensor head. It uses the local velocity, along with other parameters such as fluid type, pipe size, and Reynolds Number to calculate the average pipe velocity, and consequently, the volumetric flow rate.

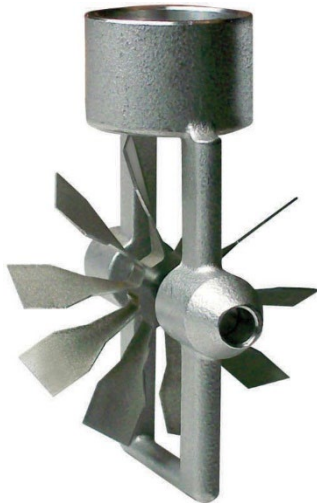

TurboPro™ Model Pro-T™-VTP

The Model PRO-T™-VTP offers you flow computer functionality in a compact field device. This multivariable instrument incorporates temperature and pressure sensors to provide an instantaneous reading of the compensated mass flow rate of gases, liquids and steam. In addition to outputs for totalized mass and alarm settings, the field-configurable electronics deliver up to three analog 4-20 mA outputs of five process measurements, including volumetric flow rate, mass flow rate, pressure, temperature and density.

TurboPro™ Model PRO-T™-VT

The Model PRO-T™-VT integrates a precision 1000 Ohm platinum RTD temperature sensor that can be used to calculate and output a compensated mass reading. This device is typically used to measure flow rates of saturated steam.

TurboPro™ Model PRO-T™-V

The Model PRO-T™-V delivers a direct reading of volumetric flow rate—generally the most cost-effective solution for liquid flow monitoring—in applications ranging from general water flows to hydrocarbon fuel flow measurement.

TurboPro™ Model PRO-T™-EM

The Model PRO-T™-EM Energy Monitoring option permits real-time calculation of energy consumption for a facility or process. The meter can be programmed to measure steam, hot water or chilled water. The Model PRO-T™-VTP flowmeter monitors one side of the process, either sent or returned, and uses the input from a second separate temperature sensor on the opposite leg of the process to calculate the change in energy. Selectable energy units include Btu, joules, calories, Watt-hours, Megawatt-hours and Horsepower-hours. The local or remote electronics indicate two temperatures, delta T, mass total and energy total.

TurboPro™ Model PRO-T™-VTEP, VETEP

Similar to PRO-T™-VTP but with the option for an external input (T or P) via RTD or 4-20mA or one of each.

Performance Specifications

Accuracy

Mass flow rate for gas and steam based on 50-100% of pressure range.

Model PRO-T™ Multiparameter Insertion Vortex Meter		
Process Variables	Liquids	Gas & Steam
Volumetric Flow Rate	± 1.2% of Rate	± 1.5% of Rate
Mass Flow Rate	± 1.5% of Rate	± 2.0% of Rate
Temperature	± 2°F (± 1°C)	± 2°F (± 1°C)
Pressure	± .3% of Full Scale	± .3% of Full Scale
Density	± .3% of Reading	± .5% of Reading

Repeatability

Mass Flow Rate.....± .2% of rate
 Volumetric Flow Rate.....± .1% of rate
 Temperature.....± .2°F (± .1°C)
 Pressure.....± .05% of full scale
 Density.....± .1% of reading

Stability Over 12 Months

Mass Flow Rate.....± .2% of rate
 Volumetric Flow Rate.....± negligible
 Temperature.....± .9°F (± .5°C)
 Pressure.....± .1% of full scale
 Density.....± .1% of reading

Response Time

Adjustable from 1 to 100 seconds.

Operating Specifications

Any gas, liquid, or steam compatible with 316L stainless steel or A105 carbon steel. Not recommended for multi-phase fluids.

Process and Ambient Temperature

Process Standard Temperature (code ST): -67 to 450°F (-55 to 238°C)
 Process High Temperature (code HT): -488 to 850°F (-267 to 454°C)
 Ambient Operating: -40 to 140°F (-40 to 60°C)
 Ambient Storage: -40 to 185°F (-40 to 85°C)

Pressure Transducer Ratings			
Full Scale Operating Pressure		Max. Over-Range Pressure	
psia	bara	psia	bara
30	2	60	4
100	7	200	14
300	20	600	40
500	35	1000	70
1000	69	2000	138
1500	100	2750	175
2500	172	5000	344



Pressure Ratings			
Style Connection	Process	Rating Code	Ordering
Compression Fitting	2-inch Male NPT	ANSI 600 lb	CNPT
	2-inch 150 lb flange	ANSI 150 lb	C150
	2-inch 300 lb flange	ANSI 300 lb	C300
	2-inch 600 lb flange	ANSI 600 lb	C600
	2-inch 900 lb flange	ANSI 900 lb	C900
Packing Gland	2-inch Male NPT	50 Psig (3.5 BarG)	PNPT
	2-inch 150 lb flange	50 Psig (3.5 BarG)	P150
	2-inch 300 lb flange	50 Psig (3.5 BarG)	P300
Packing Gland & Removable Retractor*	2-inch Male NPT	ANSI 300 lb	PNPT + RR
	2-inch 150 lb flange	ANSI 150 lb	P150 + RR
	2-inch 300 lb flange	ANSI 300 lb	P300 + RR
Packing Gland & Permanent Retractor*	2-inch Male NPT	ANSI 600 lb	PNPTR
	2-inch 150 lb flange	ANSI 150 lb	P150R
	2-inch 300 lb flange	ANSI 300 lb	P300R
	2-inch 600 lb flange	ANSI 600 lb	P600R
	2-inch 900 lb flange	ANSI 900 lb	P900R

*Retractor handle or handwheel included in retractor assembly



Power Requirements

DCL option: 12-36 VDC, 25mA, 1W max, loop powered (single output)
 DCH option: 12-36 VDC, 300mA, 9W max, (multiple outputs)
 DCHPOE option: 12-28 VDC or Power over Ethernet, 5W maximum (multiple outputs)
 AC option: 100-240 VAC, 50/60Hz line power, 5W (multiple outputs)

Display

Alphanumeric 2 line x 16 character LCD digital display Six pushbuttons for full field configuration. Pushbuttons can be operated with magnetic wand without removal of enclosure covers. Display can be mounted in 90° intervals for better viewing.

Output Signals

Analog: 4-20 mA
 Alarm: Solid state relay, 40 VDC
 Totalizer Pulse: 50 millisecond pulse, 40 VDC
 Volumetric or Loop Powered Mass: One analog, one totalizer pulse, HART
 Multivariable option: Up to three analog signals, three alarms, one totalizer pulse, HART
 Multivariable option: Modbus or BACnet process monitoring

Physical Specifications

Wetted Materials

- 316L, 302, 17-4PH, 18-8 stainless steel, tungsten carbide, sapphire, plus:
- DuPont Teflon® based thread sealant on models with pressure transducer
 - DuPont Teflon® packing on standard temperature models with packing gland
 - Graphite based packing on high temperature models with packing gland

Approvals

FM, FMC CLASS I, DIV. 1, GROUPS B,C,D
 CLASS II/III, DIV. 1, GROUPS E,F,G
 Type 4X and IP66, T6, Ta = -40 to 60°C

ATEX II 2 G Ex d IIB + H2 T6
 II 2 D EX tD A21 IP66 T85°C, Ta = -40 to 60°C

IECEX Ex d IIB + H2 T6
 Ex tD A21 IP66 T85°C, Ta = -40 to 60°C

Sizing Considerations

Piping Conditions		
Condition	Pipe Diameters, D	
	Upstream	Downstream
One 90° elbow before meter	10D	5D
Two 90° elbows before meter	15D	5D
Two 90° elbows before meter, out of plane	30D	10D
Reduction before meter	10D	5D
Expansion before meter	20D	5D
Partially open valve	30D	10D

Velocity Range

Maximum velocity, liquid: 30 feet/sec (9 meters/second)
 Minimum velocity, liquid: 0.5 foot/sec (.15 meters/second)
 Maximum velocity, gas or steam: 43 to 205 feet/sec (13 to 62 meters/sec) depending on rotor pitch
 Minimum velocity, gas or steam: 3.5 to 12 feet/sec (1 to 3.7 meters/sec) depending on rotor pitch

Consult the VorTek Instruments Sizing Program at <https://vortek.sizingapp.com> for easy calculation of flow range.

Water Minimum and Maximum Flow Rates							
Rate	Nominal Pipe Size (in)						
	2	3	6	8	12	16	24
GPM min	5	12	54	109	247	386	877
GPM max	314	691	2701	4678	10575	16524	37590
Nominal Pipe Size (mm)							
	50	80	150	200	300	400	600
m ³ /hr min	1.19	2.62	12.3	24.8	56.0	87.6	199
m ³ /hr max	71.3	157	614	1062	2402	3753	8538



Typical Air Minimum and Maximum Flow Rates (SCFM) Air at Standard Process Conditions 70°F, 14.6959 PSIA						
Pressure	Nominal Pipe Size (in)					
Rotor-R40	3	6	8	12	16	24
	7	29	51	120	198	492
0 psig	98	404	714	1660	2729	6702
	20	83	147	343	566	1401
100 psig	790	3252	5741	13313	21791	53019
	28	115	203	473	780	1927
200 psig	1494	6146	10846	25128	41083	99739
	Rotor-R30					
0 psig	8	33	59	137	227	564
	143	590	1043	2426	3984	9765
100 psig	23	95	169	393	648	1603
	1153	4746	8376	19412	31753	77152
200 psig	32	131	232	542	893	2205
	2181	8964	15814	36617	59832	145094
Rotor-R20						
0 psig	14	59	104	243	402	996
	230	951	1680	3904	6406	15665
100 psig	41	169	298	695	1144	2823
	1855	7628	13458	31168	50942	123591
	56	232	411	957	1575	3879
	3506	14397	25389	58747	95927	232348
Rotor-R10						
0 psig	25	102	181	422	696	1720
	478	1968	3476	8067	13217	32219
100 psig	71	292	516	1202	1977	4862
	3831	15728	27734	64166	104762	253698
200 psig	97	402	711	1654	2719	6678
	7230	29650	52259	120804	197092	476732

Typical Air Minimum and Maximum Flow Rates (nm3/hr) Air at Standard Conditions 20°C, 1.0133 BARA						
Pressure	Nominal Pipe Size (mm)					
Rotor-R40	80	150	200	300	400	600
	11	46	81	189	312	777
0 barg	154	639	1130	2628	4320	10607
	27	114	202	471	777	1925
5 barg	946	3898	6884	15969	26152	63694
	37	155	275	642	1059	2619
10 barg	1751	7205	12718	29476	48216	117169
	Rotor-R30					
0 barg	13	52	93	217	358	891
	226	934	1651	3839	6306	15455
5 barg	31	131	231	540	890	2204
	1382	5690	10046	23290	38115	92698
10 barg	43	178	316	736	1213	2998
	2556	10511	18548	42965	70237	170473
Rotor-R20						
0 barg	22	93	165	385	635	1574
	365	1505	2660	6179	10139	24794
5 barg	56	231	410	955	1573	3882
	2224	9149	18145	37407	61186	148520
10 barg	76	315	558	1300	2141	5275
	4110	16888	29789	68956	112643	273032
Rotor-R10						
0 barg	39	161	286	667	1099	2718
	756	3115	5502	12768	20919	50995
5 barg	97	401	709	1651	2717	6687
	4595	18874	33290	77048	125842	304938
10 barg	132	546	966	2248	3696	9082
	8481	34799	61349	141871	231535	560318

Typical Saturated Steam Minimum and Maximum Flow Rates (lb/hr)						
Pressure	Nominal Pipe Size (in)					
Rotor-R40	3	4	6	8	10	12
	25	45	105	187	300	437
5 psig	287	504	1187	2098	3357	4883
	59	104	245	435	697	1015
100 psig	1540	2702	6350	11216	17924	26034
	80	141	333	590	945	1377
200 psig	2827	4957	11643	20558	32844	47681
	Rotor-R30					
5 psig	29	51	121	214	344	501
	420	737	1735	3068	4907	7135
100 psig	68	119	281	499	799	1164
	2251	3947	9272	16373	26160	37984
200 psig	92	162	382	677	1083	1578
	4129	7238	16994	29996	47911	69532
Rotor-R20						
5 psig	52	91	215	380	610	888
	677	1189	2797	4943	7902	11485
100 psig	120	211	499	883	1414	2058
	3623	6352	14915	26328	42053	61035
200 psig	163	287	676	1197	1917	2790
	6643	11641	27317	48203	76969	111658
Rotor-R10						
5 psig	90	158	373	660	1057	1539
	1405	2464	5790	10227	16343	23736
100 psig	209	367	864	1529	2447	3561
	7490	13123	30791	54325	86735	125807
200 psig	283	497	1172	2073	3316	4825
	13719	24028	56341	99362	158587	229926

Typical Saturated Steam Minimum and Maximum Flow Rates (kg/hr)						
Pressure	Nominal Pipe Size (mm)					
Rotor-R40	80	150	200	300	400	600
	15	27	63	112	179	261
1.4 barg	225	395	929	1642	2626	3817
	23	41	98	173	277	404
5 barg	537	943	2216	3915	6257	9090
	31	55	131	232	371	541
10 barg	962	1687	3963	6999	11183	16239
	Rotor-R30					
1.4 barg	17	31	72	128	205	299
	329	577	1358	2399	3836	5575
5 barg	27	47	112	198	318	463
	785	1377	3237	5716	9134	13265
10 barg	36	63	150	266	425	620
	1405	2463	5786	10215	16318	23687
Rotor-R20						
1.4 barg	31	54	128	227	363	529
	530	930	2187	3863	6174	8968
5 barg	48	84	198	351	562	819
	1265	2217	5207	9194	14688	21322
10 barg	64	113	266	470	753	1096
	2261	3963	9303	16419	26222	38049
Rotor-R10						
1.4 barg	54	94	222	393	630	917
	1098	1925	4522	7985	12757	18520
5 barg	83	146	344	608	973	1417
	2615	4583	10755	18979	30307	43967
10 barg	111	195	460	814	1303	1895
	4672	8185	19197	33862	54055	78386

* Rotors R25 and R15 are also available



Product Disposal Information

To ensure environmental safety and compliance, please follow these disposal instructions for the product and its components:

Electronic Components:

This product contains electronics that must be recycled through approved e-waste recycling programs. Electronics can contain harmful materials and should be prevented from entering landfills. Do not place electronics in regular trash.

Metal Parts:

Any metal components can be separated and recycled through your local metal recycling facility.

Packaging Materials:

Recycle or reuse packaging materials such as cardboard or plastics, following local recycling guidelines.

For local disposal sites, refer to:

- Call2Recycle (USA, Canada)
- Earth911 (USA, Canada)
- SERI (International)

In the USA, for more information, visit:

- EPA's battery disposal guide
- EPA's electronics recycling page

By following these guidelines, you help reduce waste and support environmental sustainability.



Dimensional Outline: Pro-T™ Compression Fitting Models

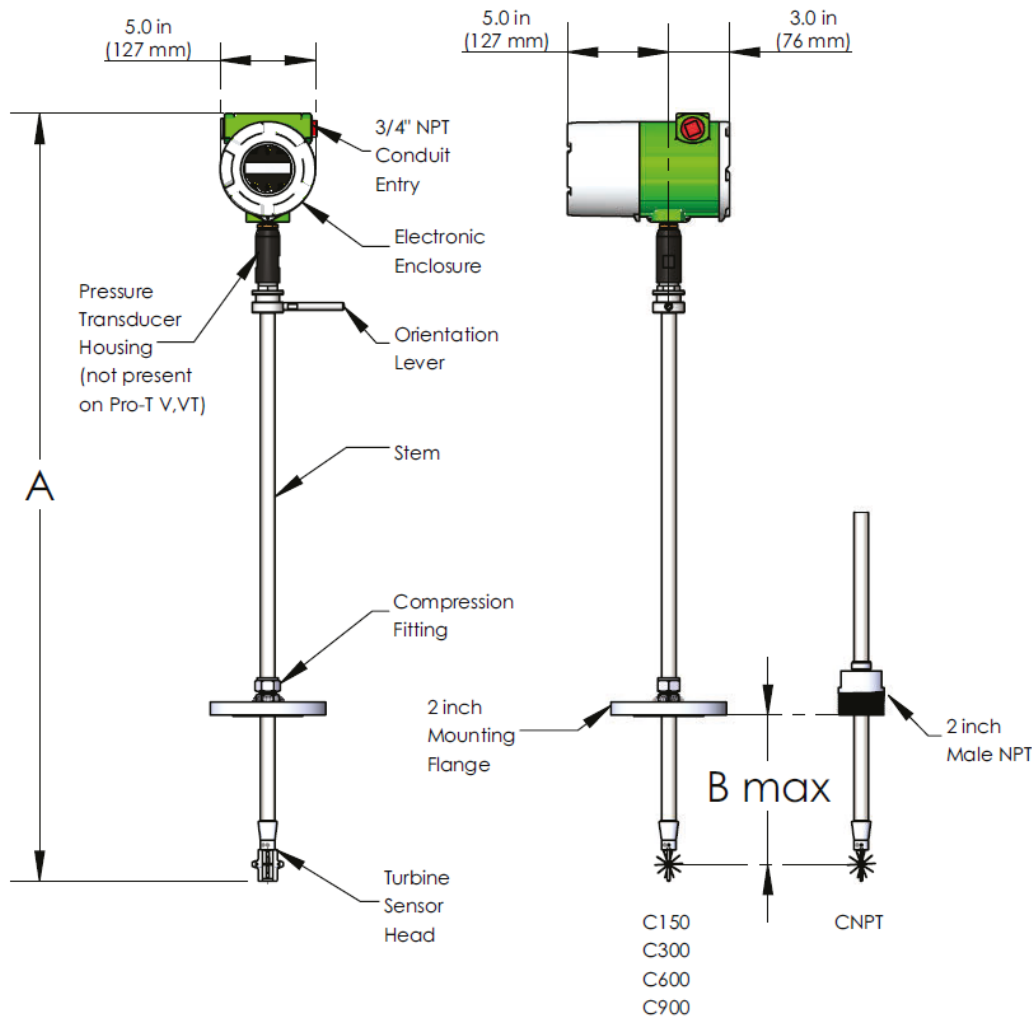

MODEL PRO-T™-V, VT, VTEP, VETEP in (mm)	CL/Compact Length		SL/Standard Length		EL/Extended Length		Weight lb (KG)		
	A	B	A	B	A	B	CL	SL	EL
CNPT, Compression Fitting, Male NPT	21.1 (536)	9.0 (229)	37.5 (953)	25.4 (645)	49.5 (1257)	37.4 (950)	13 (5.7)	14 (6.2)	15 (6.7)
C150, Compression Fitting, 150 lb. Flange	21.1 (536)	10.1 (257)	37.5 (953)	26.5 (673)	49.5 (1257)	38.5 (978)	15 (6.8)	16 (7.3)	17 (7.8)
C300, Compression Fitting, 300 lb. Flange	21.1 (536)	10.0 (254)	37.5 (953)	26.4 (671)	49.5 (1257)	38.4 (975)	17 (7.8)	18 (8.3)	19 (8.8)
C600, Compression Fitting, 600 lb. Flange	21.1 (536)	9.6 (244)	37.5 (953)	26.0 (660)	49.5 (1257)	38.0 (965)	18 (7.8)	19 (8.7)	20 (9.2)
C900, Compression Fitting, 900 lb. Flange	21.1 (536)	9.0 (229)	37.5 (953)	25.4 (645)	49.5 (1257)	37.4 (950)	31 (14.1)	32 (14.5)	33 (15)

Add 11 lb (5 KG) for remote electronics

MODEL PRO-T™-VTP in (mm)	CL/Compact Length		SL/Standard Length		EL/Extended Length		Weight lb (KG)		
	A	B	A	B	A	B	CL	SL	EL
CNPT, Compression Fitting, Male NPT	24.1 (612)	9.0 (229)	40.5 (1029)	25.4 (645)	52.5 (1334)	37.4 (950)	13 (5.7)	14 (6.2)	15 (6.7)
C150, Compression Fitting, 150 lb. Flange	24.1 (612)	10.1 (257)	40.5 (1029)	26.5 (673)	52.5 (1334)	38.5 (978)	15 (6.8)	16 (7.3)	17 (7.8)
C300, Compression Fitting, 300 lb. Flange	24.1 (612)	10.0 (254)	40.5 (1029)	26.4 (671)	52.5 (1334)	38.4 (975)	17 (7.8)	18 (8.3)	19 (8.8)
C600, Compression Fitting, 600 lb. Flange	24.1 (612)	9.6 (244)	40.5 (1029)	26.0 (660)	52.5 (1334)	38.0 (965)	18 (7.8)	19 (8.7)	20 (9.2)
C900, Compression Fitting, 900 lb. Flange	24.1 (612)	9.0 (229)	40.5 (1029)	25.4 (645)	52.5 (1334)	37.4 (950)	31 (14.1)	32 (14.5)	33 (15)

Add 11 lb (5 KG) for remote electronics



REMOVABLE RETRACTOR CAN BE USED WITH THESE MODELS

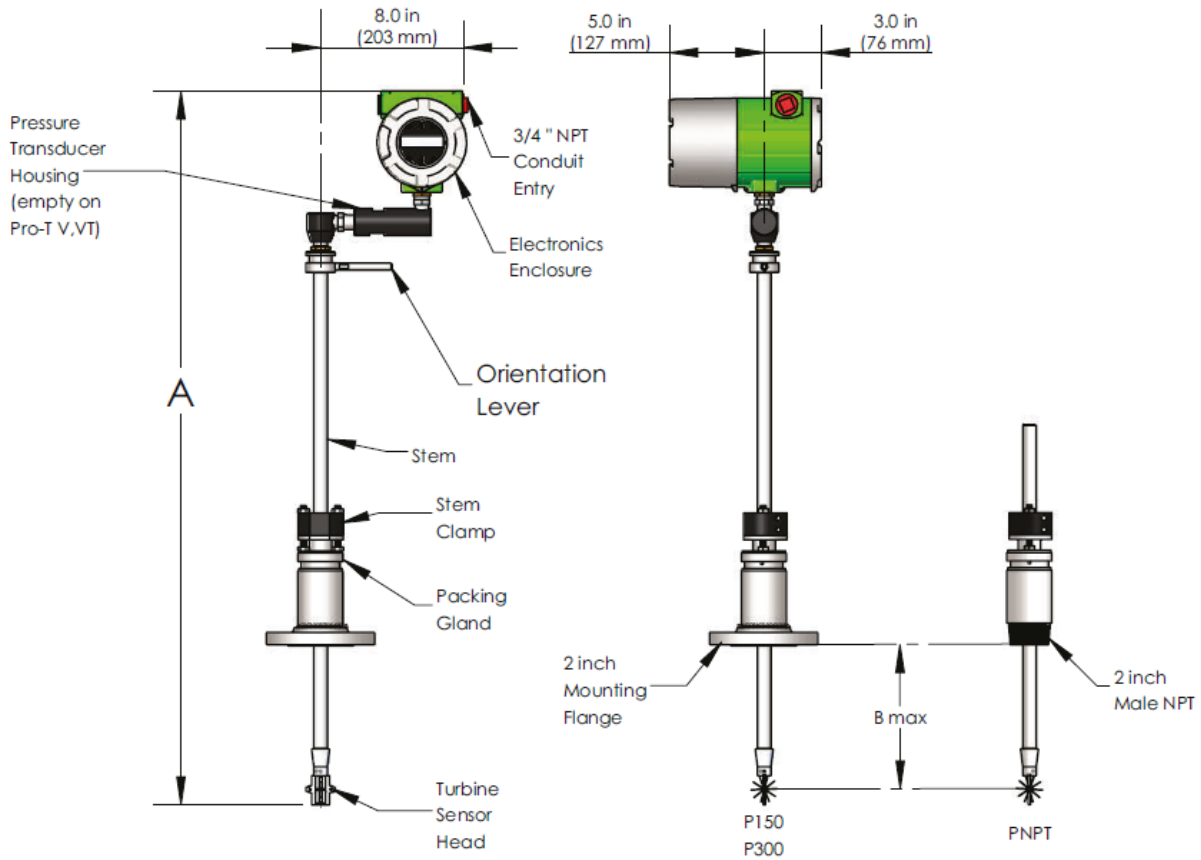

MODEL PRO-T™ in (mm)	SL/Standard Length		EL/Extended Length		Weight lb (KG)	
	A	B	A	B	SL	EL
PNPT, Packing Gland, Male NPT	40.0 (1016)	20.7 (526)	52.0 (1321)	32.7 (831)	16 (7.1)	17 (7.6)
P150, Packing Gland, 150 lb. Flange	40.0 (1016)	20.3 (516)	52.0 (1321)	32.3 (820)	21 (9.4)	22 (9.9)
P300, Packing Gland, 300 lb. Flange	40.0 (1016)	20.3 (516)	52.0 (1321)	32.3 (820)	25 (11.3)	26 (11.8)

Add 11 lb (5 KG) for remote electronics

Dimensional Outline: Pro-T™ Packing Gland Models with Permanent Retractor

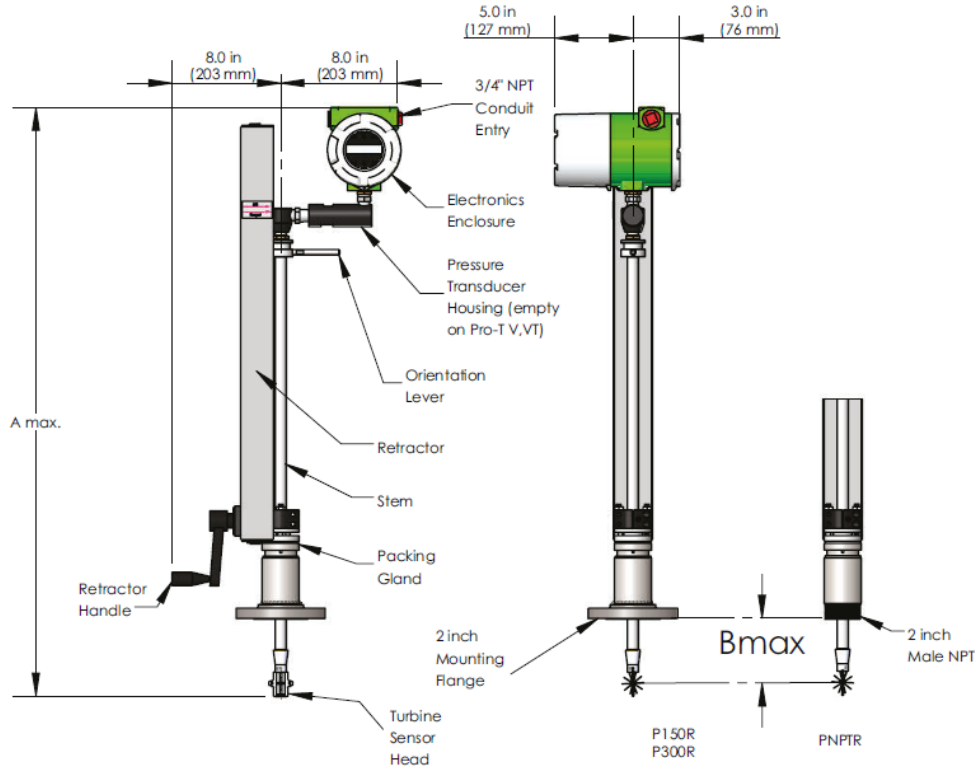

MODEL PRO-T™ in (mm) WITH PERMANENT RETRACTOR	SL/Standard Length		EL/Extended Length		Weight lb (KG)	
	A	B	A	B	SL	EL
PNPTR, Packing Gland, Male NPT	40.0 (1016)	20.7 (526)	52.0 (1321)	32.7 (831)	25 (11.5)	32 (14.5)
P150R, Packing Gland, 150 lb. Flange	40.0 (1016)	20.3 (516)	52.0 (1321)	32.3 (820)	30 (13.7)	37 (16.7)
P300R, Packing Gland, 300 lb. Flange	40.0 (1016)	20.3 (516)	52.0 (1321)	32.3 (820)	34 (15.5)	41 (18.5)

Add 11 lb (5 KG) for remote electronics
 Heavy-Duty Retractor option available upon request – consult factory

Dimensional Outline: Pro-T™ Packing Gland Models with Permanent Heavy-Duty Retractor

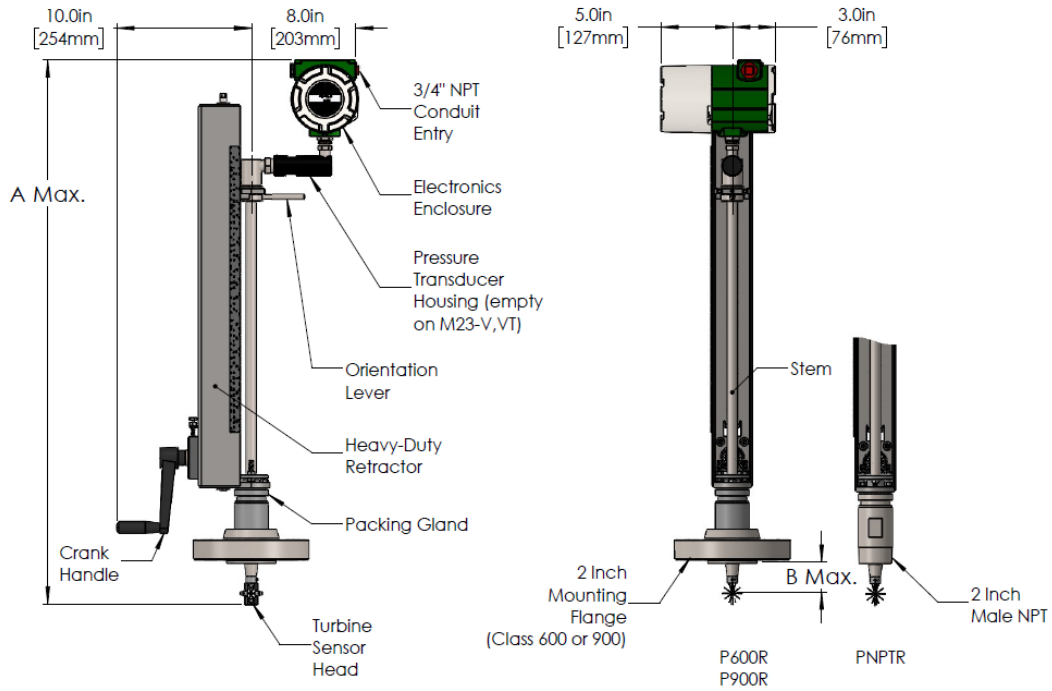

MODEL PRO-T™ in (mm) WITH PERMANENT HEAVY-DUTY RETRACTOR	SL/Standard Length		EL/Extended Length		Weight lb (KG)	
	A	B	A	B	SL	EL
PNPTR, Packing Gland, Male NPT	40.0 (1016)	20.4 (519)	52.0 (1321)	32.4 (823)	32 (14.5)	38 (17.2)
P600R, Packing Gland, 600 lb. Flange	40.0 (1016)	20.1 (511)	52.0 (1321)	32.1 (816)	42 (19.1)	48 (21.8)
P900R, Packing Gland, 900 lb. Flange	40.0 (1016)	20.1 (511)	52.0 (1321)	32.1 (816)	55 (24.9)	61 (27.7)

Add 11 lb (5 KG) for remote electronics

Dimensional Outline: Remote Electronics Option

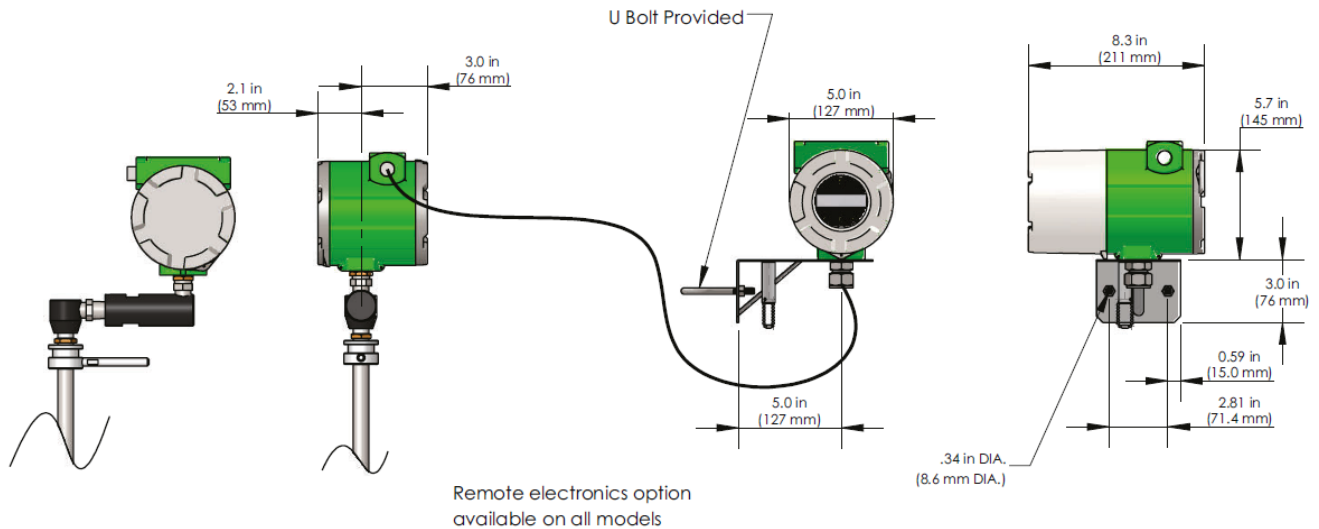

Model Number Information - TurboPro™ Model PRO-T™ Insertion Mass Vortex Flowmeter

Parent Number Code

PRO-T™ Insertion Turbine Flowmeter

Feature 1: Multivariable Options

V Volumetric Flowmeter for liquid, gas, and steam
VT Velocity and Temperature Sensors
VTP Velocity, Temperature, and Pressure Sensors
VTEP Velocity, Temperature, and External 4-20mA Input (T or P)
VETEP Velocity, External RTD Temperature Input, External 4-20mA Input (T or P)
VT-EM Energy Output Options
VTP-EM Energy Options with Pressure Sensor
VTEP-EM Velocity, Temperature, External 4-20mA Input (T or P)
VETEP-EM Velocity, External RTD Temperature Input, External 4-20mA Input (T or P)

Feature 2: Probe Length

CL Compact Length **SL** Standard Length **EL** Extended Length

Feature 3: Electronics Enclosure

L NEMA 4x IP66 Enclosure **R(I)** Remote Electronics NEMA 4X IP66 Enclosure, Specify cable length in parentheses, Standard 50ft

Feature 4: Display Options

DD Digital Display and Programming Buttons

Feature 5: Input Power

DCL 12-36 VDC, 25mA, 1W max. – required on loop powered meters, 1AHL only
DCH 12-36 VDC, 300mA, 9W max. – use with 1AH, 1AM, 1AB, 3AH, 3AM, 3AB
DCHPOE 12-28 VDC or Power Over Ethernet, 5W max. – required on 1AMIP, 1ABIP, 3AMIP, 3ABIP
AC 100-240 VAC, 50/60 Hz line power, 5W max. – use with 1AH, 1AM, 1AB, 3AH, 3AM, 3AB

Feature 6: Output

1AHL Loop powered option – one analog output (4-20mA), one scaled frequency, one pulse, HART, DCL input power only
1AH One analog output (4-20mA), one alarm, one pulse, HART Communication Protocol, DCH or AC option only *
1AM One analog output (4-20mA), one alarm, one pulse, MODBUS RTU Communication Protocol, DCH or AC option only *
1AMIP One analog output (4-20mA), one alarm, one pulse, MODBUS TCP/IP Communication Protocol, DCHPOE option only *
1AB One analog output (4-20mA), one alarm, one pulse, BACnet MS/TP Communication Protocol, DCH or AC option only *
1ABIP One analog output (4-20mA), one alarm, one pulse, BACnet/IP Communication Protocol, DCHPOE option only *
3AH Three analog outputs (4-20mA), three alarms, one pulse, HART, VT or VTP option only, DCH or AC option only *
3AM Three analog outputs (4-20mA), three alarms, one pulse, MODBUS RTU, VT or VTP option only, DCH or AC option only *
3AMIP Three analog outputs (4-20mA), three alarms, one pulse, MODBUS TCP/IP, VT or VTP option only, DCHPOE option only *
3AB Three analog outputs (4-20mA), three alarms, one pulse, BACnet MS/TP, VT or VTP option only, DCH or AC option only *
3ABIP Three analog outputs (4-20mA), three alarms, one pulse, BACnet/IP, VT or VTP option only, DCHPOE option only * *Includes scaled frequency output

Feature 7: Temperature Options

ST Standard Temperature – Process temperature -330° to 500° F (-200° to 260° C) **HT** High Temperature – Process temperature up to 750° F (400° C)

Feature 8: Pressure Options

P0 No Pressure Sensor **P4** Maximum 500 psia (34 bara), Proof 1000 psia (64 bara)
P1 Maximum 30 psia (2 bara), Proof 60 psia (4 bara) **P5** Maximum 1500 psia (100 bara), Proof 2500 psia (175 bara)
P2 Maximum 100 psia (7 bara), Proof 200 psia (14 bara) **P6** Maximum 2500 psia (172 bara), Proof 5000 psia (344 bara)
P3 Maximum 300 psia (20 bara), Proof 600 psia (41 bara) **P7** Maximum 1000 psia (69 bara), Proof 2000 psia (138 bara)

Feature 9: Process Connections

CNPT Compression, 2 inch NPT	PJ10 Packing Gland, 2 inch JIS 10K Flange	*Heavy-Duty Retractor Option Available **Stem Safety Clamp Option Recommended
CJNPT Compression, 2 inch NPT JIS	P300 Packing Gland, 2 inch 300# Flange	
C150 Compression, 2 inch 150# Flange	P40 Packing Gland, DN50 PN40 Flange	
C16 Compression, DN50 PN16 Flange	PJ20 Packing Gland, 2 inch JIS 20K Flange	
CJ10 Compression, 2 inch JIS 10K Flange	PNPTR Packing Gland, 2 inch NPT, Retractor* (PNPTHR)	
C300 Compression, 2 inch 300# Flange	PJNPTR Packing Gland, 2 inch NPT JIS, Retractor* (PJNPTHR)	
C40 Compression, DN50 PN40 Flange	P150R Packing Gland, 2 inch 150# Flange, Retractor*	
CJ20 Compression, 2 inch JIS 20K Flange	P16R Packing Gland, DN50 PN16 Flange, Retractor*	
C600 Compression, 2 inch 600# Flange	PJ10R Packing Gland, 2 inch JIS 10K Flange, Retractor*	
C63 Compression, DN50 PN63 Flange	P300R Packing Gland, 2 inch 300# Flange, Retractor*	
C900 Compression, 2 inch 900# Flange	P40R Packing Gland, DN50 PN40, Retractor*	
CJ30 Compression, 2 inch JIS 30K Flange	PJ20R Packing Gland, 2 inch JIS 20K Flange, Retractor*	
PNPT Packing Gland, 2 inch NPT	P600R Packing Gland, 2 inch 600# Flange, Heavy-Duty Retractor**	
PGJPT Packing Gland, 2 inch NPT JIS	P63R Packing Gland, DN50 PN63 Flange, Heavy-Duty Retractor**	
P150 Packing Gland, 2 inch 150# Flange	PJ30R Packing Gland, 2 inch JIS 30K Flange, Heavy-Duty Retractor**	
P16 Packing Gland, DN50 PN16 Flange	P900R Packing Gland, 2 inch 900# Flange, Heavy-Duty Retractor** (includes safety clamp)	

Feature 10: Rotor Options

R40 Gas or Steam, Vmin = 3.5 ft/sec, Vmax = 43 ft/sec, 40° pitch* **R15** Gas or Steam, Vmin = 8.5 ft/sec, Vmax = 134.6 ft/sec, 15° pitch*
R30 Gas or Steam, Vmin = 4.0 ft/sec, Vmax = 62.5 ft/sec, 30° pitch* **R10** Gas or Steam, Vmin = 12 ft/sec, Vmax = 205 ft/sec, 10° pitch*
R25 Gas or Steam, Vmin = 5.0 ft/sec, Vmax = 80 ft/sec, 25° pitch* **L40** Liquid, Vmin = 1 ft/sec, Vmax = 30 ft/sec, 40° pitch*
R20 Gas or Steam, Vmin = 7.0 ft/sec, Vmax = 100 ft/sec, 20° pitch* *Velocities based on atmospheric conditions

